

TYPE OF GRINDING MACHINE	
MODEL OF GRINDING MACHINE	
SERIAL No. OF GRINDING MACHINE	
DIRECTION OF WHEEL ROTATION	
POSITION OF OIL FILLER AND ANY OBSTRUCTION ON SPINDLE HEAD	
WORKPIECE SPECIAL FEATURES AND MATERIAL SPECIFICATION	
WORKING TEMPERATURE OF GRINDING WHEEL SPINDLE BEARINGS	
DO YOU REQUIRE DIAFORM TO SUPPLY A SUITABLE WHEELGUARD FOR THIS ARRANGEMENT?	
COMPLETE SPECIFICATION OF ALL EXISTING SCREW HOLES, DOWELS, TENONS AND TEESLOTS IN SPINDLE HEAD	

No.	DIMENSIONS	No.	DIMENSIONS	No.	DIMENSIONS
1		12		23	
2		13	∅	24	
3		14		25	
4	Over Nut	15		26	
5	∅	16		27	
6		17	Degrees	28	
7		18		29	
8		19		30	∅
9		20		31	x Deep
10		21		32	x Deep
11		22			

COLUMN

PLAN VIEW

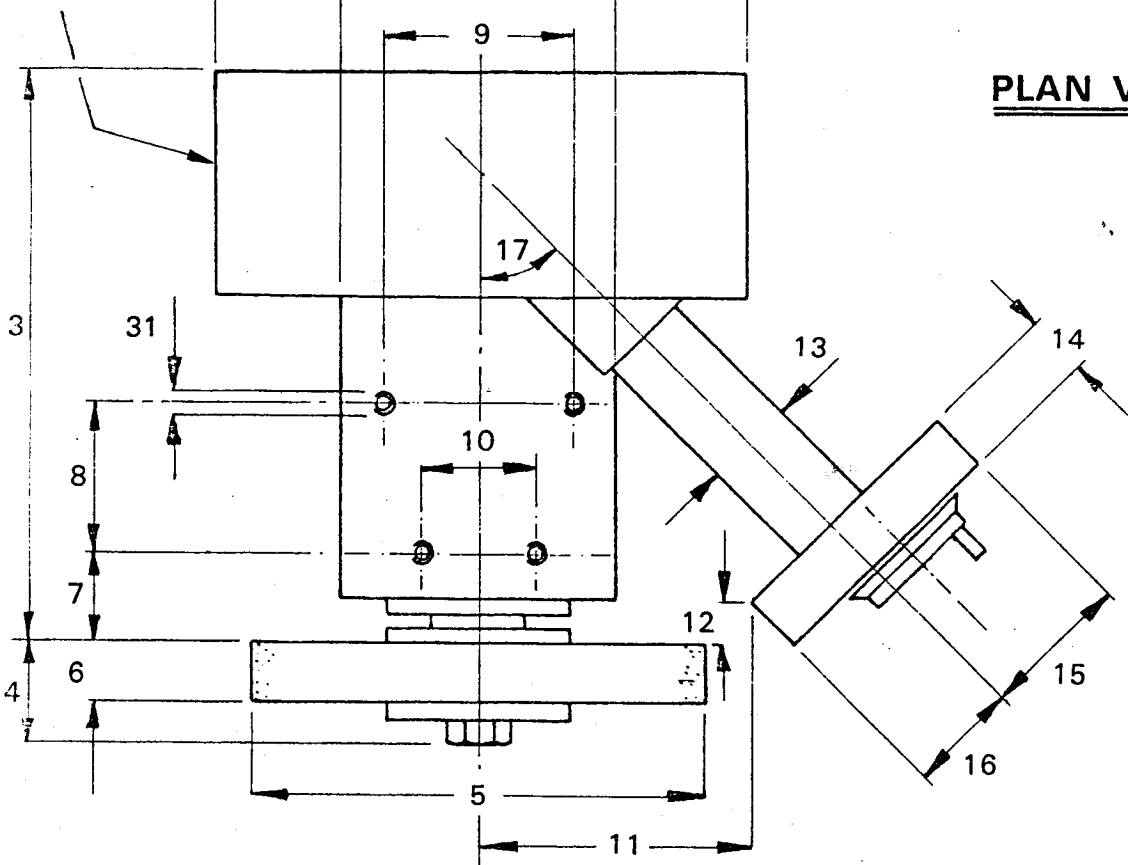

FRONT VIEW
WITH
WHEEL REMOVED

SPINDLE HEAD

GRINDING WHEEL

SIDE VIEW

